



量程 CAPACITY (t) H H1 H2 H3 C1 C2 C3 C4 C4

10、15、20、30、40、50、60 200 150 140 12 83.5 64 43.8 M8 99

汽车衡、轨道衡、轴重秤

Truck scale, railway scale, axle-load scale

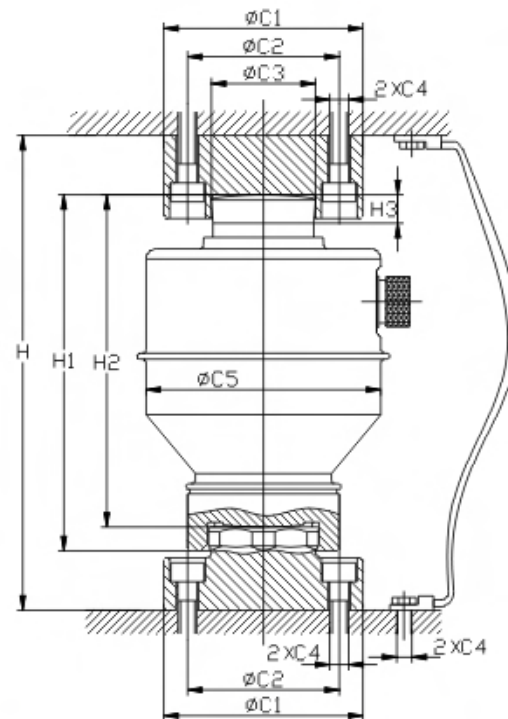

TECHNICAL PARAMETER

4Wires:Exc+(蓝,Blue);Exc-(黑,Black);Sig+(白,White);Sig-(红,Red)

精度等级 Accuracy	C3	安全负载 Safe Overload	150% F.S.
重复性 Repeatability	0.01%F.S	推荐激励电压 Rated Excitation	9~12V DC (20V Max.)
蠕变 (30分钟) Creep error(30 min)	0.02%F.S	绝缘电阻 Insulation Resistance	1000MΩ
零点温度影响 TCO	0.015%F.S/10°C	材质 Material	合金钢、不锈钢 alloy steel or stainless steel
灵敏度温度影响 TC SPAN	0.015%F.S/10°C	通讯方式 Communication mode:	RS 485
数据刷新频率 Data update frequency	10HZ	最大信号传输距离 Max. transmission distance:	1200m
通讯波特率 Baud rate	9600BPS(19200BPS)	密封等级 Protection class:	IP69K
工作温度 Operating Temperature	-30°C~+70°C		