

叉车秤、配料秤、低平面台秤  
Forklift scale, Blending scale, low platform scale

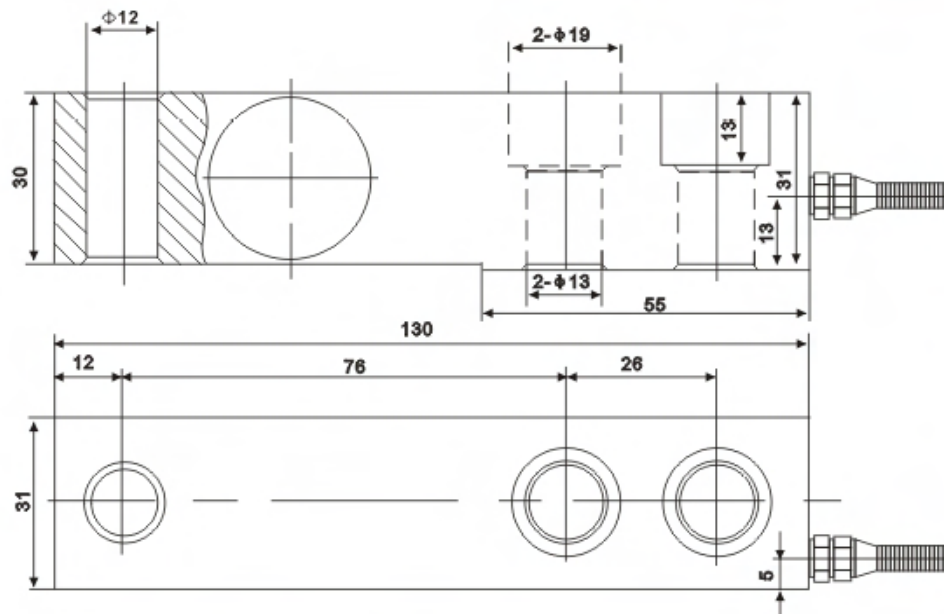

## TECHNICAL PARAMETER

4Wires:Exc+(红,Red);Exc-(黑,Black);Sig+(绿,Green);Sig-(白,White)

额定载荷 Rated capacities(Emax)	1t	温度补偿范围 Temperature range, compensated	-10℃~+40℃
灵敏度 Sensitivity	2.4±0.002mV/V	工作温度范围 Temperature range, operating	-30~+70℃
综合误差 Total error	±0.03%F.S	安全过载 Maximum safe overload	150%F.S
蠕变(30分钟)Creep error (30min)	±0.03%F.S	极限过载 Ultimate overload	200%F.S
零点平衡 Zero balance	±1%F.S	推荐激励电压 Excitation,recommend	10~12V DC
零点温度影响 TCO	±0.02%F.S/10℃	最大激励电压 Excitation,maximum	15V DC
输出温度影响 TC SPAN	±0.02%F.S/10℃	防封等级 Protection class	IP66
输入阻抗 Input impedance	400± Ω	材质 Construction	合金钢Alloy Steel
输出阻抗 Output impedance	352±3Ω	电缆 Cable	Length: 1.5m
绝缘电阻 Insulation impedance	≥5000MΩ		Diameter: φ 5mm