

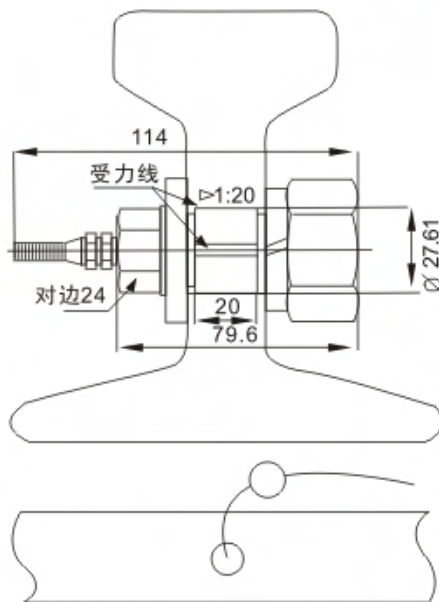

轨道衡塞入式识别器
Railway scale insert -identifier



TECHNICAL PARAMETER

4Wires:Exc+(红,Red);Exc-(黑,Black);Sig+(绿,Green);Sig-(白,White)

额定载荷 Rated capacities(E _{max})	200kN	温度补偿范围 Temperature range, compensated	-10℃~+40℃
灵敏度 Sensitivity	1.7±0.1mV/V	工作温度范围 Temperature range, operating	-30~+70℃
综合误差 Total error	±0.5%F.S	安全过载 Maximum safe overload	150%F.S
蠕变(30分钟)Creep error (30min)	±0.1%F.S	极限过载 Ultimate overload	200%F.S
零点平衡 Zero balance	±1%F.S	推荐激励电压 Excitation,recommend	10~12V DC
零点温度影响 TCO	±0.1%F.S/10℃	最大激励电压 Excitation,maximum	15V DC
输出温度影响 TC SPAN	±0.2%F.S/10℃	防封等级 Protection class	IP67
输入阻抗 Input impedance	383±5Ω	材质 Construction	不锈钢Stainless Steel
输出阻抗 Output impedance	352±3Ω	电缆 Cable	Length:14m
绝缘电阻 Insulation impedance	≥5000MΩ		Diameter: φ 6mm