

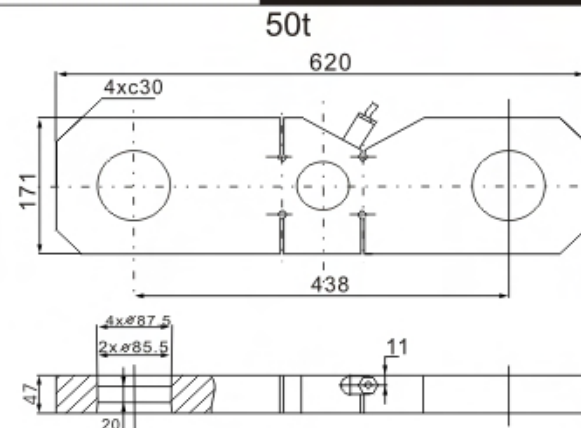

15~30t

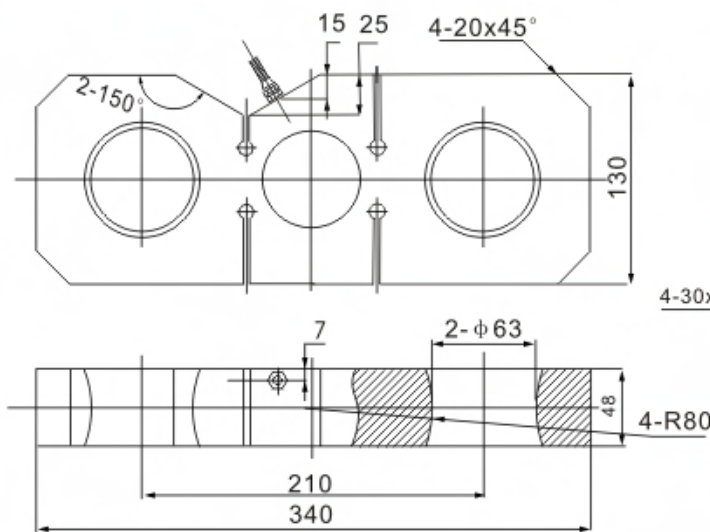

50t

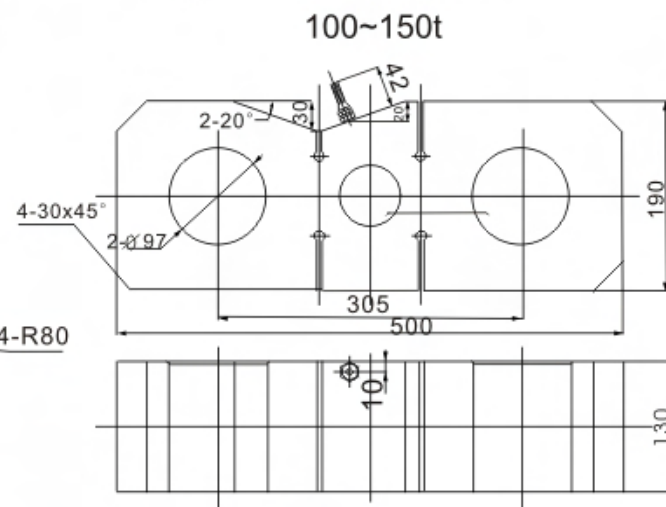

100~150t



吊钩秤、料斗秤、包装秤、过载限位

Crane scale, hopper scale, packing scale, overload limiter

TECHNICAL PARAMETER

4Wires:Exc+(红,Red);Exc-(黑,Black);Sig+(绿,Green);Sig-(白,White)

额定载荷 Rated capacities(E _{max})	15,20,30,50,100,150t	温度补偿范围 Temperature range, compensated	-10℃~+40℃
灵敏度 Sensitivity	2.0±0.002mV/V(15~50t);1.5±0.01mV/V(100~150t)	工作温度范围 Temperature range, operating	-30~+70℃
综合误差 Total error	±0.05%F.S	安全过载 Maximum safe overload	120%F.S
蠕变(30分钟)Creep error (30min)	±0.02%F.S	极限过载 Ultimate overload	150%F.S
零点平衡 Zero balance	±1%F.S	推荐激励电压 Excitation,recommend	10~12V DC
零点温度影响 TCO	±0.02%F.S/10℃	最大激励电压 Excitation,maximum	15V DC
输出温度影响 TC SPAN	±0.02%F.S/10℃	防封等级 Protection class	IP67
输入阻抗 Input impedance	400±20Ω	材质 Construction	合金钢Alloy Steel
输出阻抗 Output impedance	352±3Ω	电缆 Cable	Length:12m (15~30t,100~150t),10m(50t)
绝缘电阻 Insulation impedance	≥5000MΩ		Diameter: φ 5mm(15~30t,100~150t), φ 8mm(50t)